

## 600V Half-Bridge Driver

### PRODUCT SUMMARY

- $V_{\text{OFFSET}}$  600 V max.
- $I_{\text{O+/-}}$  450 mA/ 950 mA
- $V_{\text{OUT}}$  10 V - 20 V
- $t_{\text{on/off (typ.)}}$  680 ns/200 ns
- **Deadtime (typ.)** 520 ns

### GENERAL DESCRIPTION

The SLM2184S is a high voltage, high speed power MOSFET and IGBT drivers with dependent high- and low-side referenced output channels. Proprietary HVIC and latch immune CMOS technologies enable ruggedized monolithic construction. The logic input is compatible with standard CMOS or LSTTL output, down to 3.3 V logic. The output drivers feature a high pulse current buffer stage designed for minimum driver cross conduction. The floating channel can be used to drive an N-channel power MOSFET or IGBT in the high-side configuration which operates up to 600 V.

### FEATURES

- Floating channel designed for bootstrap operation
- Fully operational to +600 V
- Tolerant to negative transient voltage, dV/dt immune
- Gate drive supply range from 10 V to 20 V
- Undervoltage lockout
- 3.3 V, 5 V, and 15 V logic compatible
- Cross-conduction prevention logic
- Matched propagation delay for both channels
- Internal set deadtime
- Shutdown input turns off both channels
- RoHS compliant
- SOP-8 package

### TYPICAL APPLICATION CIRCUIT

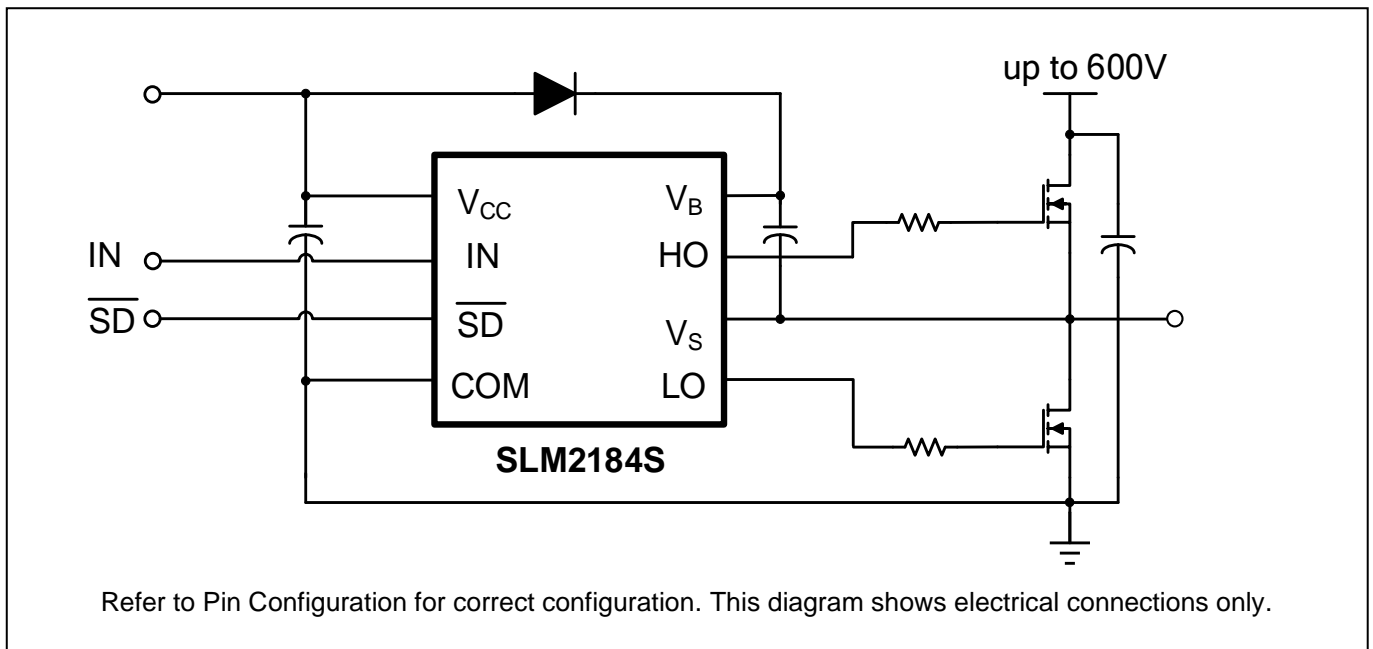

## PIN CONFIGURATION

Package	Pin Configuration (Top View)
SOP-8	

## PIN DESCRIPTION

No.	Pin	Description
1	IN	Logic input to control the high-side and low-side gate driver output (HO/LO). HO: In phase with IN. LO: Out of phase with IN.
2	$\overline{SD}$	Input logic for shutdown control. If $\overline{SD}$ is low, both high side and low side gate output is low.
3	COM	Low-side return
4	LO	Low-side gate drive output
5	V <sub>CC</sub>	Low-side and logic fixed supply
6	V <sub>S</sub>	High-side floating supply return
7	HO	High-side gate drive output
8	V <sub>B</sub>	High-side floating supply

## ORDERING INFORMATION

Industrial Range: -40°C to +125°C

Order Part No.	Package	QTY
SLM2184SCA-13GTR	SOP8, Pb-Free	2500/Reel

**FUNCTIONAL BLOCK DIAGRAM**

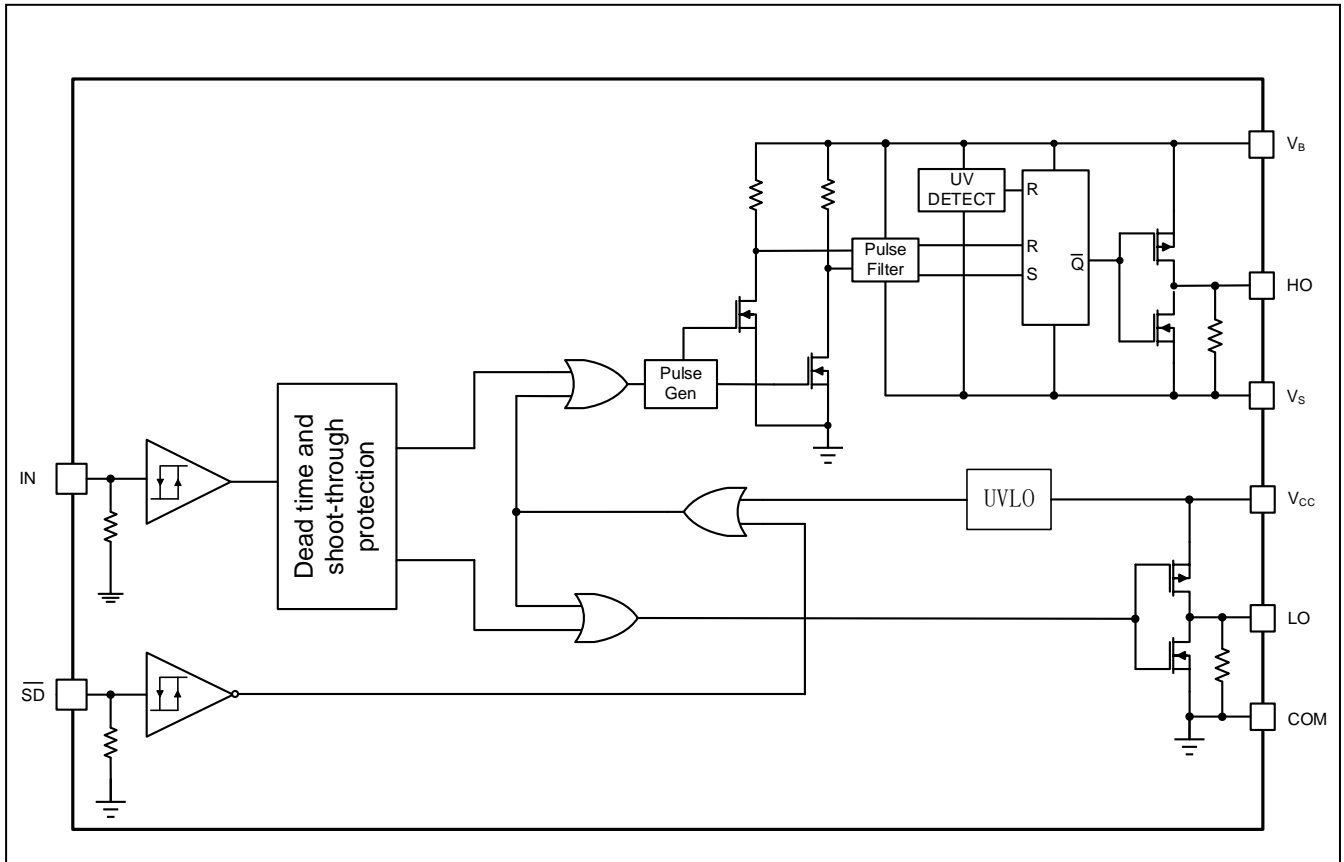

**ABSOLUTE MAXIMUM RATINGS**

Symbol	Definition	Min.	Max.	Units
V <sub>B</sub>	High-side floating absolute voltage	-0.3	625	V
V <sub>S</sub>	High-side floating supply offset voltage	V <sub>B</sub> - 25	V <sub>B</sub> + 0.3	
V <sub>HO</sub>	High-side floating output voltage	V <sub>S</sub> - 0.3	V <sub>B</sub> + 0.3	
V <sub>CC</sub>	Low-side and logic fixed supply voltage	-0.3	25	
V <sub>LO</sub>	Low-side output voltage	-0.3	V <sub>CC</sub> + 0.3	
V <sub>IN</sub>	Logic input voltage (IN & $\overline{SD}$ )	-0.3	V <sub>CC</sub> + 0.3	
dV <sub>S</sub> /dt	Allowable offset supply voltage transient	---	50	V/ns
P <sub>D</sub>	Package power dissipation @ T <sub>A</sub> ≤ +25°C	---	0.625	W
θ <sub>JA</sub>	Thermal resistance, junction to ambient	---	200	°C/W
T <sub>J</sub>	Junction temperature	---	150	°C
T <sub>S</sub>	Storage temperature	-55	150	
T <sub>L</sub>	Lead temperature (soldering, 10 seconds)	---	300	

Note: Absolute maximum ratings indicate sustained limits beyond which damage to the device may occur. All voltage parameters are absolute voltages referenced to COM. The thermal resistance and power dissipation ratings are measured under board mounted and still air conditions.

**RECOMMENDED OPERATION CONDITIONS**

Symbol	Definition	Min.	Max.	Units
V <sub>B</sub>	High-side floating absolute voltage	V <sub>S</sub> + 10	V <sub>S</sub> + 20	V
V <sub>S</sub>	High-side floating supply offset voltage		600	
V <sub>ST</sub>	Transient high-side floating supply offset voltage	-40 (within 400ns)	600	
V <sub>HO</sub>	High-side floating output voltage	V <sub>S</sub>	V <sub>B</sub>	
V <sub>CC</sub>	Low-side and logic fixed supply voltage	10	20	
V <sub>LO</sub>	Low-side output voltage	0	V <sub>CC</sub>	
V <sub>IN</sub>	Logic input voltage (IN & $\overline{SD}$ )	0	V <sub>CC</sub>	
T <sub>A</sub>	Ambient temperature	- 40	125	°C

Note: The input/output logic timing diagram is shown in Figure 1. For proper operation the device should be used within the recommended conditions. The V<sub>S</sub> offset rating is tested with all supplies biased at a 15 V differential.

## DYNAMIC ELECTRICAL CHARACTERISTICS

$V_{BIAS}$  ( $V_{CC}$ ,  $V_{BS}$ ) = 15 V,  $C_L$  = 1000 pF and  $T_A$  = 25°C unless otherwise specified.

Symbol	Parameter	Condition	Min.	Typ.	Max.	Unit
$t_{on}$	Turn-on propagation delay	$V_S = 0$ V	---	680	820	ns
$t_{off}$	Turn-off propagation delay	$V_S = 0$ V	---	200	400	
$t_{sd}$	Shutdown propagation delay		---	160	220	
$t_r$	Turn-on rise time		---	40	80	
$t_f$	Turn-off fall time		---	20	40	
DT	Deadtime, LS turn-off to HS turn-on & HS turn-on to LS turn-off		400	520	650	
MT	Delay matching, HS & LS turn-on/off		---	---	60	

## STATIC ELECTRICAL CHARACTERISTICS

$V_{BIAS}$  ( $V_{CC}$ ,  $V_{BS}$ ) = 15 V and  $T_A$  = 25°C unless otherwise specified. The  $V_{IN}$ ,  $V_{TH}$ , and  $I_{IN}$  parameters are referenced to COM. The  $V_O$  and  $I_O$  parameters are referenced to COM and are applicable to the respective output leads: HO or LO.

Symbol	Parameter	Condition	Min.	Typ.	Max.	Unit
$V_{IH}$	Logic "1" input voltage	$V_{CC} = 10$ V to 20V	2.5	---	---	V
$V_{IL}$	Logic "0" input voltage		---	---	0.8	
VSD, TH+	SD input positive going threshold		2.5	---	---	
VSD, TH-	SD input negative going threshold		---	---	0.8	
$V_{OH}$	High level output voltage, $V_{BIAS} - V_O$	$I_O = 2$ mA	---	0.05	0.2	
$V_{OL}$	Low level output voltage, $V_O$		---	0.02	0.1	
$I_{LK}$	Offset supply leakage current	$V_B = V_S = 600$ V	---	---	50	$\mu$ A
$I_{QBS}$	Quiescent $V_{BS}$ supply current	$V_{IN} = 0$ V	---	60	78	
$I_{QCC}$	Quiescent $V_{CC}$ supply current		---	210	305	
$I_{IN+}$	Logic "1" input bias current	$V_{IN} = 5$ V	---	8	10	
$I_{IN-}$	Logic "0" input bias current	$V_{IN} = 0$ V	---	---	5	
$V_{CCUV+}$ $V_{BSUV+}$	$V_{CC}$ & $V_{BS}$ supply undervoltage positive going threshold		8	8.9	9.8	V

Symbol	Parameter	Condition	Min.	Typ.	Max.	Unit
$V_{CCUV}$ - $V_{BSUV}$	$V_{CC}$ & $V_{BS}$ supply undervoltage negative going threshold		7.4	8.2	9	
$I_{O+}$	Output high short circuit pulsed current	$V_O = 0\text{ V}$ , $V_{IN} = V_{IH}$ , $PW \leq 10\ \mu\text{s}$	320	450		mA
$I_{O-}$	Output low short circuit pulsed current	$V_O = 15\text{ V}$ , $V_{IN} = V_{IL}$ , $PW \leq 10\ \mu\text{s}$	680	950		

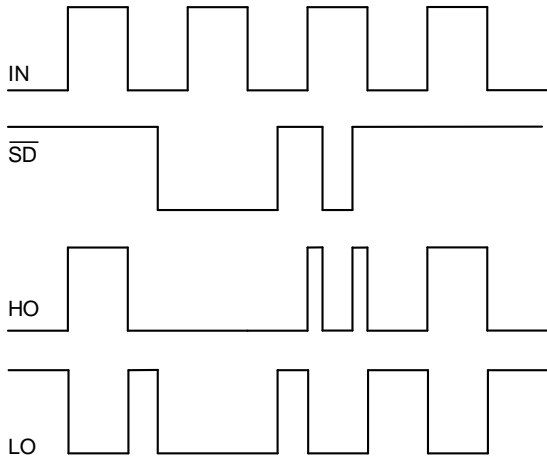

Figure 1. Input/Output Timing Diagram

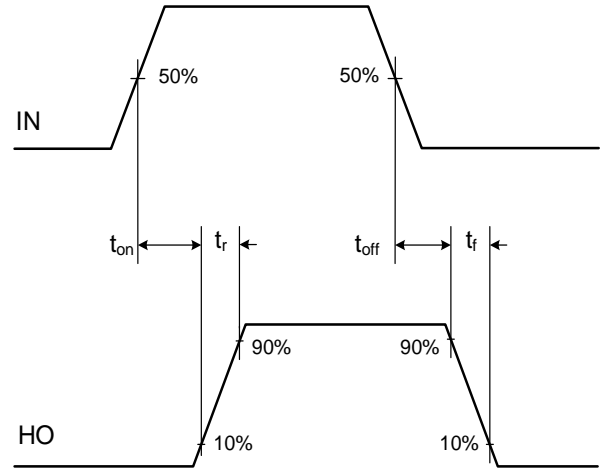

Figure 2. High Side Switching Time Waveform

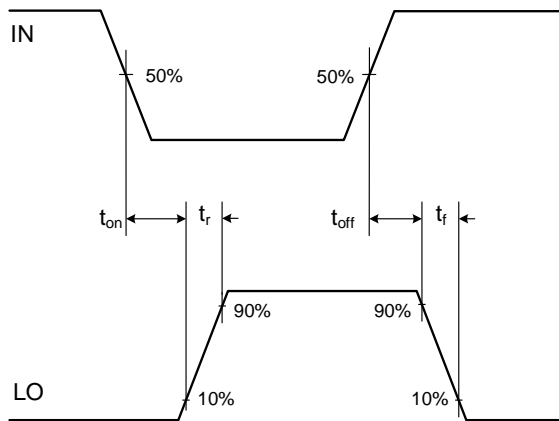

Figure 3. Low Side Switching Time Waveform

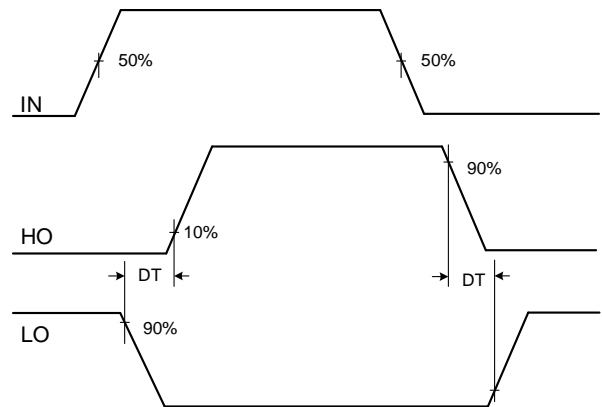

Figure 4. Dead Time Waveform

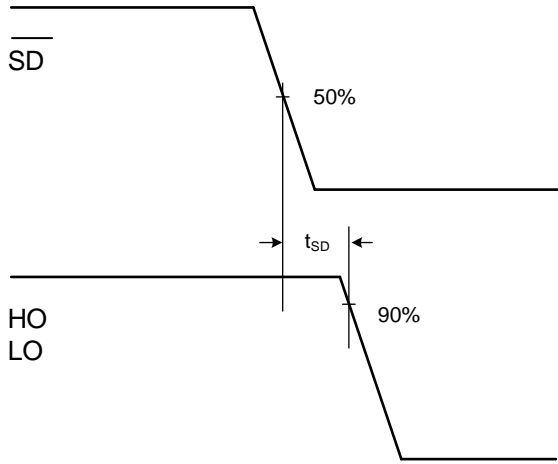

Figure 5. Shutdown Time Waveform

**PACKAGE CASE OUTLINES**

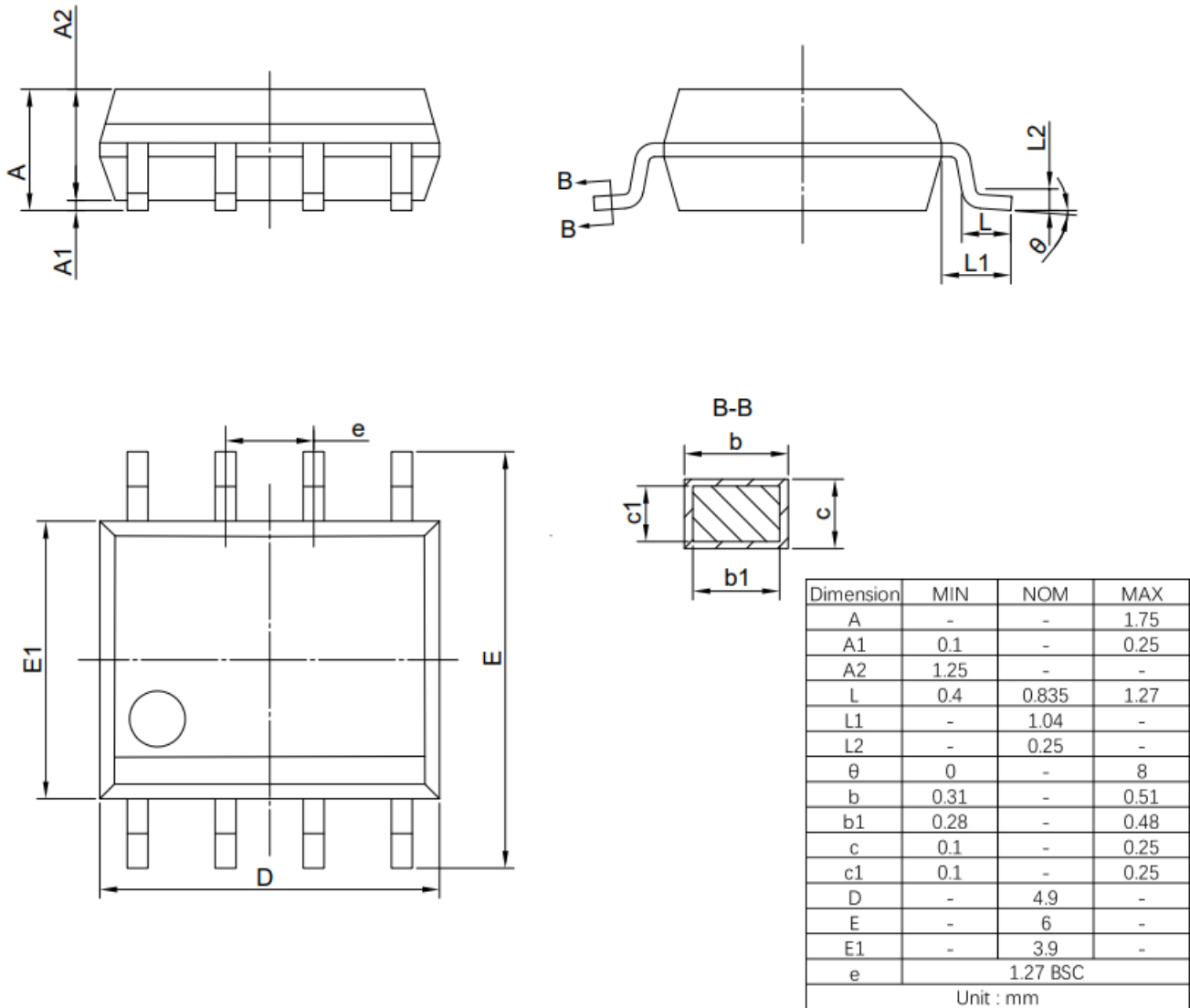

Figure 6. SOP8 Outline Dimensions



## REVISION HISTORY

Note: page numbers for previous revisions may differ from page numbers in current version

Page or Item	Subjects (major changes since previous revision)
<b>Rev 1.0 Datasheet, 2019-8-27</b>	
Whole document	New company logo released
Page 1	Remove "Figure 1." and "June 2019"
<b>Rev 1.1 Datasheet, 2021-9-7</b>	
Whole datasheet	Update the Logo and format
Page 1	Remove package option PDIP-8
Page 2	Remove the order part No. SLM2184SCA-GT and SLM2184SDA-GT in the ordering information
Page 3	Updated the Functional Block Diagram
Page 5	Update the $t_{off}$ value in the Dynamic Electrical Characteristics. Update the $I_{OCC}$ , $I_{IN+}$ , $I_{O+}$ and $I_{O-}$ value in the Static Electrical Characteristics.
<b>Rev 1.2 Datasheet, 2022-12-29</b>	
Page 8	SOP8 Outline Dimensions Update